

# **(BSR)/OPEI B175.5-202X (N9) – (Standard) for Outdoor Power Equipment – Internal Combustion Engine–Powered Hand-Held Edger – Safety and Environmental Requirements**

## **1. Scope and Purpose**

### **1.1. Scope**

The requirements of this Standard apply to:

- a) Internal combustion engine–powered, hand-held edgers having at least one ground-support and a rigid cutting blade that has a blade tip circle of not more than 254 mm (10 in).
- b) Internal combustion engine–powered, hand-held, multi-purpose units when configured as an edger.

This standard is not applicable to gasoline-powered edgers and edger-trimmers that employ a cutting means:

- a) That is made of nonmetallic flexible line; or
- b) That ~~is consisting~~consists of more than one piece, e.g., pivoting chains or flail blades.
- c) That is made of a solid, circular blade, e.g., circular saw blade.

This standard is also not applicable to non-hand-held edgers.

NOTE – English conversions are shown in brackets and are included for information only.

The requirements of this standard do not cover ~~cutting attachments~~blades not approved for use by the equipment manufacturer. However, this standard may be used by a component manufacturer to qualify after-market ~~cutting attachments~~blades. Should the manufacturer of after-market ~~cutting attachments~~blades choose to comply with this standard, the manufacturer shall conduct the tests relating to the ~~cutting-~~attachments~~blades~~ on the units they recommend them for and keep records related to the test results.

The effective implementation date of this standard shall be two (2) years after the publication date and shall apply to all products built after that date. Manufacturers may also comply with this standard any time after the approval date.

### **1.2. Purpose**

The purpose of this standard is to establish safety and environmental requirements for internal combustion engine–powered, hand-held, edgers.

## 2. Normative References

The following standards contain provisions which, through reference in this text, constitute provisions of this American National Standard. For dated references, only the edition cited applies. For undated references, the latest edition of the referenced document (including any amendments) applies.

ANSI/ASTM E29-13 (2019), *Standard Practice for Using Significant Digits in Test Data to Determine Conformance with Specifications*

~~ANSI Z87.1, American National Standard for Occupational and Educational Personal Eye and Face Protection Devices~~

~~IEC 61032:1997, Protection of Persons and Equipment by Enclosures – Probes for Verification~~

IEC 61672-1:2013, *Electroacoustics – Sound level meters – Part 1: Specifications*

IEC 61672-2:2013, *Electroacoustics – Sound level meters – Part 2: Pattern evaluation tests*

~~ISO 13857:2008 (reaffirmed 2011): Safety of machinery – Safety distances to prevent hazard zones being reached by upper and lower limbs~~

ISO 22867: *Forestry and garden machinery - Vibration test code for portable hand-held machines with internal combustion engines - Vibration at the handles*

ISO 22868: *Forestry and garden machinery - Noise test code for portable hand-held machines with internal combustion engines – Engineering method (Grade 2 accuracy)*

ISO 11806, *Agricultural and forestry machinery – Safety requirements and testing for portable, hand-held, powered brush-cutters and grass trimmers – Part 1: Machines fitted with an integral combustion engine*

~~ISO 6531, Machinery for forestry – Portable chain saws – Vocabulary~~

~~ISO 7112, Machinery for forestry – Portable brush-cutters and grass trimmers – Vocabulary~~

~~ISO 20643:2005, Mechanical vibration – Hand-held and hand-guided machinery – Principles for evaluation of vibration emission~~

~~ISO 8041-1:2017, Human response vibration – Measuring instrumentation – Part 1: General purpose vibration meters~~

~~ISO 5349-2:2001, Mechanical vibration – Measurement and evaluation of human exposure to hand-transmitted vibration – Part 1: General requirements~~

~~ISO 16063-21:2003, Methods for the calibration of vibration and shock transducers – Part 21: Vibration calibration by comparison with a reference transducer~~

ISO 8893, *Forestry machinery – Portable brush-cutters and grass-trimmers – Engine performance and fuel consumption*

ISO 1431-1:2012, *Rubber, vulcanized or thermoplastic – Resistance to ozone cracking – Part 1: Static and dynamic strain testing*

SAE J335-2012: Multiposition Small Engine Exhaust System Fire Ignition Suppression

SAE J184\_1998, *Qualifying A Sound Data Acquisition System (Surface Vehicle Recommended Practice)*

UL 969:2012, *Marking and labeling systems*

[UL 60745-1, Standard for Hand-Held Motor-Operated Electric Tools – Safety – Part 1: General Requirements](#)

U.S. Department of Agriculture Forest Service, Standard for Spark Arresters for Internal Combustion Engines 5100-1 ([USDA FS 5100-1](#))

### 3. Definitions

- 3.1. **Blade:** A rotating cutting device made of rigid material with cutting edges.
- 3.2. **Blade retainer:** Mechanism which holds the blade to the driving member.
- 3.3. **Blade shield:** Structure covering a portion of the blade arc.
- 3.4. **Blade thrust:** The sudden forward or backward motion of the unit, which may occur when the blade jams or catches on an object such as a rock.
- 3.5. **Blade tip circle:** The path described by the outermost point of the blade as it moves about its axis.
- 3.6. **Clutch:** A mechanism for connecting and disconnecting a driven member to and from a rotating source of power
- 3.7. **Debris deflector:** Additional shielding made of flexible material fitted to the unit to protect the operator from thrown objects.
- 3.8. **Depth of cut:** Vertical location of the blade-tip circle relative to the surface level. See Figure 7.
- 3.9. **Driveshaft housing:** A structure that encloses and supports the drive shaft and that connects the engine to the blade.
- 3.10. **Dry weight:** Weight of the unit with empty fuel and oil tank(s) and with blade and blade guard(s) installed.
- 3.11. **Edger (unit):** Grass/soil trimming machine where the blade operates in a plane approximately perpendicular to the ground.
- 3.12. **Fuel Tank:** A storage vessel ~~constructed of any material~~ that is an integral part of the product that is used to supply fuel to engines. A fuel tank does not include assembled components such as a fuel cap, fuel lines, gauges, grommets, seals, vents or valves.
- 3.13. **Guard:** Part of the unit ~~of or~~ component incorporated to provide protection for the operator.
- 3.14. **Hand-held:** A unit with a dry weight under 16.0 kg (25.37 lbs)A unit that during operation is supported and controlled by the user, having no more than

two wheels, for which the operator needs to provide support and/or attitudinal control ~~for the edger~~ throughout the performance of its intended function-.

- 3.15. Handle(s):** A structure that enables the operator to hold and control the unit during operation.
- 3.15.1. Adjustable handle:** Handle whose position can be modified either by movement or by rotation.
- 3.15.2. Front handle:** Handle located towards the blade. See Figure 1.
- 3.15.3. Rear handle:** Handle located furthest away from the blade. See Figure 1. The rear handle contains the throttle control.
- 3.16. May:** Indicates permissive condition.
- 3.17. Maximum engine speed:** Engine speed at wide open throttle, using carburetor setting according to the manufacturer's recommendation, or 133% of the maximum power speed, whichever is less.
- 3.18. Maximum power speed:** Engine speed at which maximum ~~corrected~~ ~~brake power is obtained.~~ ~~Maximum~~ power ~~speed~~ is obtained in accordance with ISO 8893.
- 3.19. Muffler:** Device for reducing engine exhaust noise and directing the flow of the exhaust ~~gasses~~~~gases~~.
- 3.20. Multi-purpose unit:** A unit which is configurable as two or more types of outdoor power equipment. For example, a hand-held string trimmer with a changeable portion of the equipment that transforms the units into a hand-held edger.
- 3.21. ~~Normal operation:~~** ~~Use of the unit which is reasonably foreseeable, as seen by the ordinary user, and which is consistent with such activities as cutting grass, starting, stopping, fueling, or connecting to (or disconnecting from) a power source.~~
- 3.22. Occasional use:** Infrequent ~~of or~~ moderate, non-income use.
- 3.23. On/Off or stop control:** A control that allows the engine to run or stop.
- 3.24. Power head:** Power source for the unit.
- 3.25. Throttle:** A device that adjusts the volume of fuel and air mixture delivered to the combustion chamber of an internal combustion engine.
- 3.26. Throttle control:** A device activated by the operator to regulate the throttle.
- 3.27. Throttle control latch:** A device to temporarily set the throttle in a partially open position to aid in starting the engine.
- 3.28. Throttle control lock-out:** A device which prevents the unintentional activation of the throttle control unless the operator releases it.
- 3.29. Throttle control linkage:** A mechanism that transmits motion from the throttle control to the throttle.

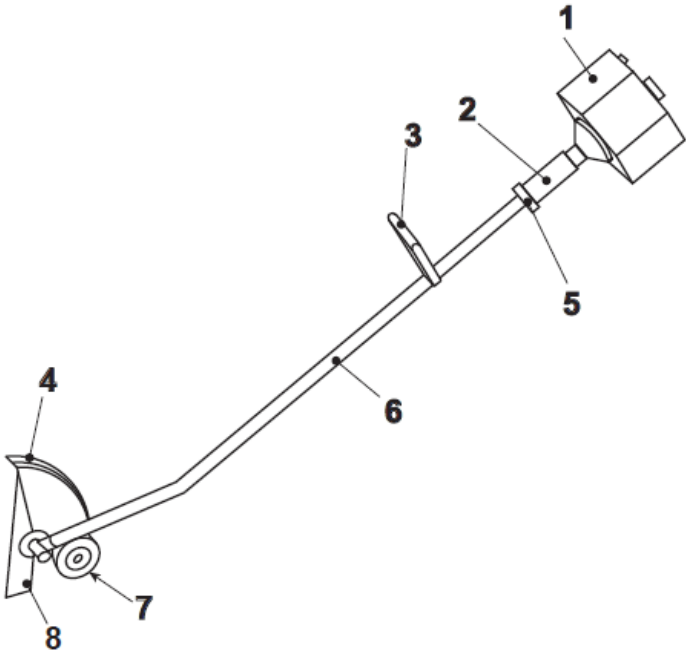

**Key**

- 1 Engine (motor)
- 2 Rear handle
- 3 Front handle
- 4 Guard
- 5 On/Off Stop Control
- 6 Shaft housing
- 7 Support wheel (depth wheel)
- 8 Cutting means

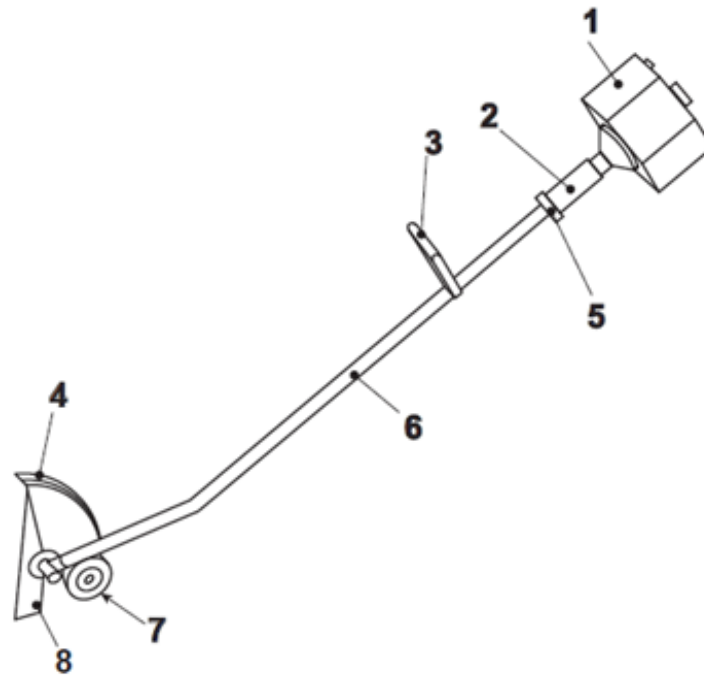

**KEY**

- 1 Power head (engine)
- 2 Rear handle
- 3 Front handle
- 4 Blade shield
- 5 On/Off stop control
- 6 Shaft housing
- 7 Support wheel
- 8 Blade

**Figure 1: Hand-held Edger**

## **4. Handles**

### **4.1. General Requirements**

The edger shall have a handle for each hand. A handle may be an integral part of the unit or driveshaft housing. These handles shall be designed such that:

- a) They can be fully gripped by an operator when wearing gloves; and
- b) They provide the necessary sureness of grip by their shaping and surface.

### **4.2. Dimensional Requirements**

The gripping surface of handles shall be at least 100 mm (3.94 in) long. On closed or U-shaped handles this dimension is related to the inner width of the gripping surface. The

gripping length of closed or U-shape handles shall comprise any length that is straight or curved at a radius of greater than 100 mm (3.94 in), together with any blend radius, but not more than 10 mm (0.39 in) at either or both ends of the gripping surface. There shall be a minimum radial clearance of 25 mm (0.98 in) around the gripping length. See Figure 2 a).

If a-any other part containing the engine of the unit complies with the dimensions above, it may be considered as a handle.

Where appropriate, the part of the handle containing the throttle control shall be counted as part of the handle gripping length. Finger grip or similar superimposed profiles shall not affect the method of calculating handle gripping length. If handles are adjustable to different positions, it shall not be possible to fix them in a position which contravenes other provisions of this standard.

For a straight centrally supported handle (i.e. "T" type), the gripping length shall be calculated as follows (see Figure 2 b):

- a) For handles with a circumference (not including the support) of less than 80 mm (3.15 in), the gripping length is the sum of the two parts of the gripping length "X" + "Y";
- b) For handles with a circumference (not including the support) of 80 mm (3.15 in) or more, the gripping length is the complete length "Z" from end to end.

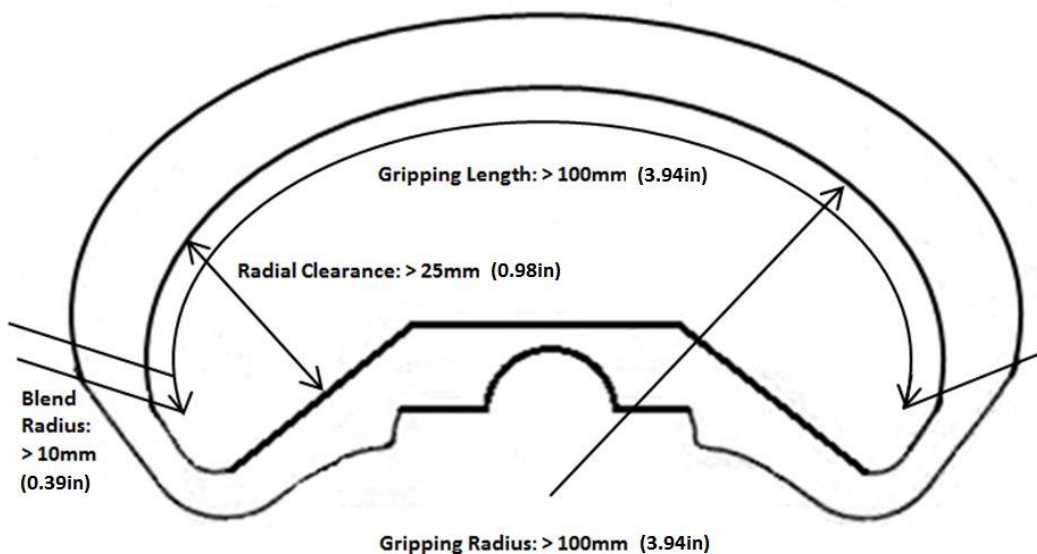

Figure 2a: Example of handle dimensions on closed or U-shaped handles

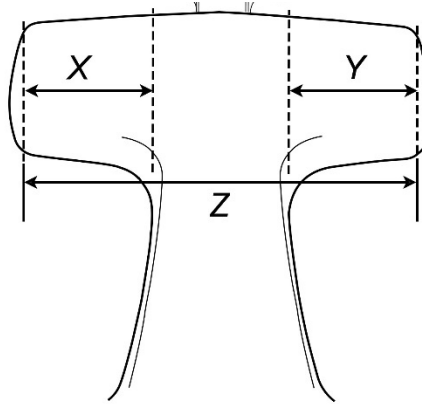
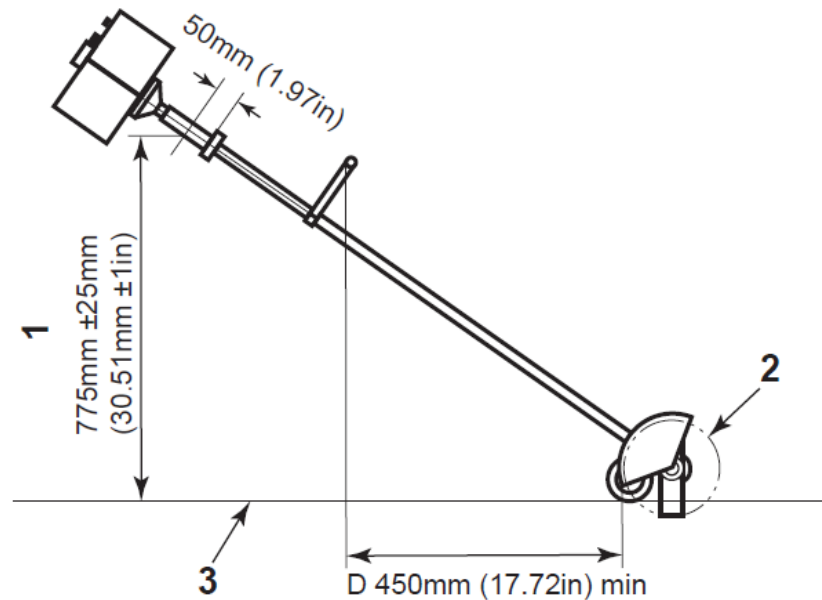

Figure 2b: Example of centrally supported handle

Figure 2: Examples of handle dimensions

Handles shall be located so that the distance (D), measured in a horizontal plane, between the rearmost portion of the blade tip circle and the rear of the front handle grip area set to the foremost position (as defined by the manufacturer) is at least 450 mm (17.7 in). The height of  $775 \pm 25$  mm ( $30.5 \pm 1$  in) shall be met at the lower contour of the rear handle 50 mm (2 in) upwards from where the gripping length starts. See Figure 3.



Key

- 1 Rear handle height
- 2 Blade-tip circle
- 3 Hard, flat and level test surface

Figure 3: Hand-held Edger, dimension distance D



## 5. Power-Driven Components

### 5.1. Requirements

All power-driven components, except any part of a component functioning in contact with the soil, shall be guarded so that the operator will not inadvertently contact them when starting or during normal operation of the unit as described in the operator's manual.

Contact with any power-driven component is not allowed.

### 5.2. Test Procedure

The location and accessibility of these power-driven components shall be verified by inspection, using a probe in accordance with IEC 6203161032, Probe B. The probe shall be applied to any opening protecting a power-driven component using a force of  $10\text{ N} \pm 2\text{ N}$  ( $2.25\text{ lbf} \pm 0.45\text{ lbf}$ ).

~~Contact with any power-driven component is not allowed.~~

## 6. Hot Surfaces

### 6.1. Requirements

When tested in accordance with Section 6.2, the temperature requirements of this section apply.

The temperature of handles and continuously held controls shall not exceed  $43^{\circ}\text{C}$  ( $109^{\circ}\text{F}$ ) ~~when measured at an ambient temperature of  $20^{\circ}\text{C} \pm 3^{\circ}\text{C}$  ( $68^{\circ}\text{F} \pm 5.4^{\circ}\text{F}$ )~~. Other controls and surfaces that may be contacted during normal operation in accordance with the manufacturer's recommendations shall not exceed  $55^{\circ}\text{C}$  ( $131^{\circ}\text{F}$ ) ~~when measured at an ambient temperature of  $20^{\circ}\text{C} \pm 3^{\circ}\text{C}$  ( $68^{\circ}\text{F} \pm 5.4^{\circ}\text{F}$ )~~.

Other metallic surfaces of the unit that have a temperature of over  $80^{\circ}\text{C}$  ( $176^{\circ}\text{F}$ ), or other plastic parts that have a temperature of over  $94^{\circ}\text{C}$  ( $201^{\circ}\text{F}$ ), ~~when measured at an ambient temperature of  $20^{\circ}\text{C} \pm 3^{\circ}\text{C}$  ( $68^{\circ}\text{F} \pm 5.4^{\circ}\text{F}$ )~~ are considered hot surfaces.

Normal operation of the unit in accordance with the manufacturer's recommendations shall not cause the operator to come into unintentional contact with a contiguous hot surface greater than  $10\text{ cm}^2$  ( $1.55\text{ in}^2$ ). The contiguous hot surface area can be curved or irregular, when evaluated according to Annex A.

Such a hot surface shall be guarded from unintentional contact if the tip or the conical surface of the test cone shown in Figure 4 can contact a contiguous hot surface area of more than  $10\text{ cm}^2$  ( $1.55\text{ in}^2$ ) ~~of the contiguous hot surface area~~.

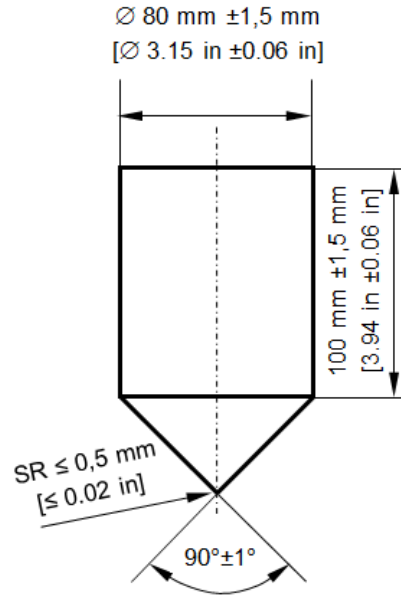

**Figure 4: Hot surfaces test cone**

Maintenance and adjustment procedures as described in the manufacturer's instruction manual are considered intentional acts and are excluded from the provisions of this section.

The exhaust pipe (outlet) is not considered a surface that may be intentionally or inadvertently contacted during normal operation.

## 6.2. Test Procedure

The test shall be conducted without the influence of sunlight, with an ambient air speed of max. 3 m/s (6.7 mi/hr), and at 20°C ± 3°C (68°F ± 5.4°F) ambient temperature.

Prepare the unit for testing by cycling the engine for 5 seconds at idling speed and 5 seconds at maximum engine speed until the surface temperature stabilizes within 5°C (9°F).

Measure the surface temperatures and apply the test cone shown in Figure 4 as described in Annex A.

## 7. Engine Exhaust

### 7.1. Exhaust Gases

#### 7.1.1. Requirements

The engine exhaust shall not be directed towards the operator during normal operation in accordance with the manufacturer's recommendation.

#### 7.1.2. Test Procedure

Exhaust direction shall be verified by inspection.

## 7.2. Spark-Arresting Mufflers

### 7.2.1. Requirements

The edger may be equipped with or have provisions for a spark-arresting muffler.

### 7.2.2. Test Procedure

If ~~an edger~~the unit is equipped with or has provisions for a spark arresting muffler, it shall meet the specifications and performance requirements in USDA FS\_5100-1 when tested in accordance with SAE J335.

## 8. Guards and Blade Shield

### 8.1. General Requirements

All guards and the blade shield(s) shall be permanently attached to the unit and shall not be detachable without the use of tools, or the construction of the unit shall be such that it cannot be used without the guard or shield in its intended position.

### 8.2. Minimum Blade Shield Dimension Requirements~~Dimensions~~

When the unit is in the operating position for edging, the blade shall be shielded (as a minimum) to the extent shown in Figure 5. ~~and the requirements of the thrown objects protection test shall be fulfilled as described in Section 9.~~

Dimensions (A) and (B) shall be such to comply with the requirements of Section 9.  
Dimension (C) shall be a minimum 10 mm (0.39 in).

For units with a forward rotating blade, dimension (B) shall be greater than 0 degrees.

For units with a reverse rotating blade, dimension (A) shall be greater than or equal to 0 degrees, and dimension (B) shall be greater than or equal to 110 degrees.

When other parts and/or unit structures provide shielding equivalent to this minimum requirement, they shall be considered as part of this shielding.

If the blade shield(s) is adjustable, the blade shield(s) requirements must be met in all positions.

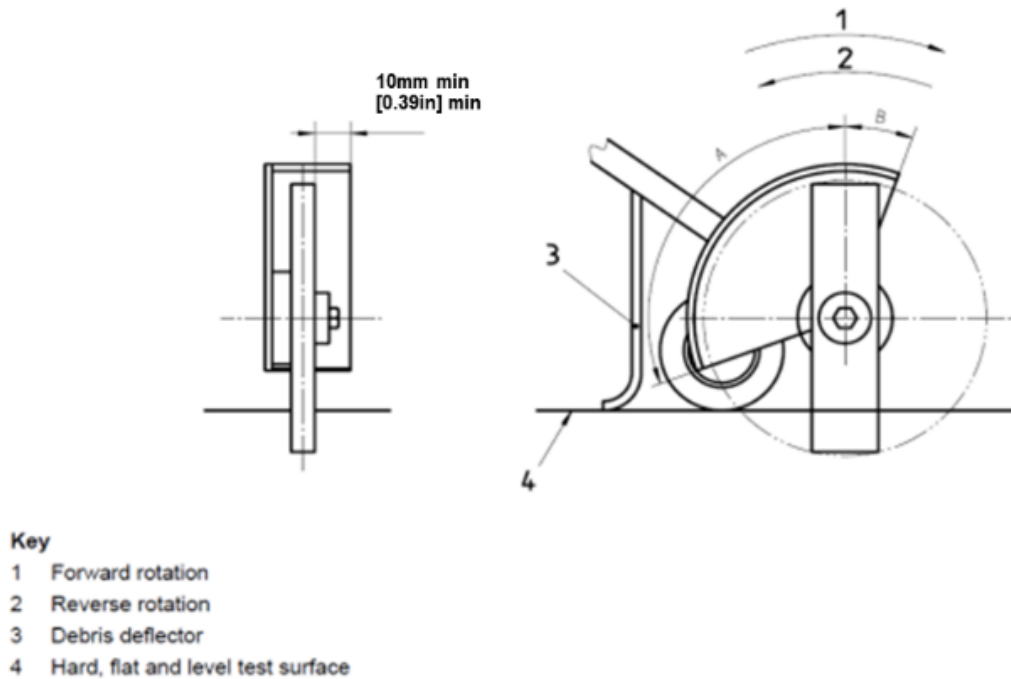

~~For units with a forward rotating blade the following dimensions apply:  
A, As required to meet Section 9. May be supplemented by support wheel, debris deflector or other components.  
B > 0°~~

~~For units with a reverse rotating blade the following dimensions apply:  
A ≥ 0°, B ≥ 110°, as required to meet Section 9.~~

**Figure 5: Minimum guard dimension**

### 8.3. Blade Shield Strength

#### 8.3.1. Requirements

The blade shield(s) that is described in section 8.2 ~~for the blade~~, and any mounting means provided for such guardingshielding, shall withstand the ball-impact test in Section 8.3.2 without cracking or deformation such that the function of the blade shield is affected.

#### 8.3.2. Test Procedure

The ball-impact test shall be conducted using a 50 ~~+1-0~~ mm (2.0 ~~±0.05~~ in) diameter smooth steel sphere with a mass of approximately 0.45 kg (1.12 lbs). If the component being tested can be struck from above, and is at an angle of less than 45° to the horizontal, the sphere shall be allowed to fall vertically from rest to strike the component. Otherwise, the sphere shall be suspended by a cord and allowed to fall

from rest as a pendulum to strike the component. In either case, the vertical travel of the sphere shall be 1300 ~~+0-5~~ mm (51 ~~± 0.2~~ in).

Shields and/or mountings shall be conditioned at the test temperature for 4 hours:

- a) Metallic shields and/or mounts shall be tested at 20°C ± 5.6°C (68°F ± 10°F);
- b) Nonmetallic shields and/or mountings shall be tested at 40°C ± 2°C (104°F ± 4°F) and at -5°C ± 3°C (23°F ± 5.4°F)

Metallic shields and/or mounts shall be impacted once at the prescribed test temperature. The same nonmetallic shield and/or mount shall be impacted once at each temperature.

## 8.4. Debris Deflector Retention Strength

### 8.4.1. Requirements

Where a debris deflector of flexible material is fitted, it shall pass the force test in Section 8.4.2 without cracking or separating from the edger, nor being permanently deformed such that any of the requirements of this standard would not be met.

### 8.4.2. Test Procedure

A force equal to the ~~weight of the edger (with empty tanks)~~dry weight of the unit shall be applied for 10 ~~seconds~~ over the width of the deflector in a direction that produces the maximum stress on the deflector.

## 9. Thrown Objects Protection Test

### 9.1. Requirements

When the edger is positioned in accordance to Figures ~~6 and 7~~, there shall be no line of sight contact with the leading edge of the edger blade when viewed from the operator position through the operator zone cut-out. Construction/assembly gaps of 3 mm (0.12 in) or less shall be ignored.

### 9.2. Test Procedure

The edger shall be positioned on a flat and level surface as shown in Figure 3. The height of 775 ± 25 mm (30.5 ± 1 in) shall be met at the lower contour of the rear handle 50 mm (2 in) upwards from where the gripping length starts.

The edger shall be adjusted to 50 % of its depth of cut as shown in Figure 7.

A panel with an operator zone cutout as defined in figure 6 shall be positioned perpendicular to the test surface and blade tip circle at a distance of 850 mm (33.5 in) rearwards from the rear edge of the cutting means.

Dimension x for the operator zone cut out is the distance between the cutting plane and the parallel plane containing the centerline of the rear handle.

EDITORIAL NOTE: 39.9" should be 3.94" and 200mm should be 2000mm. These dimensions will be updated before publication

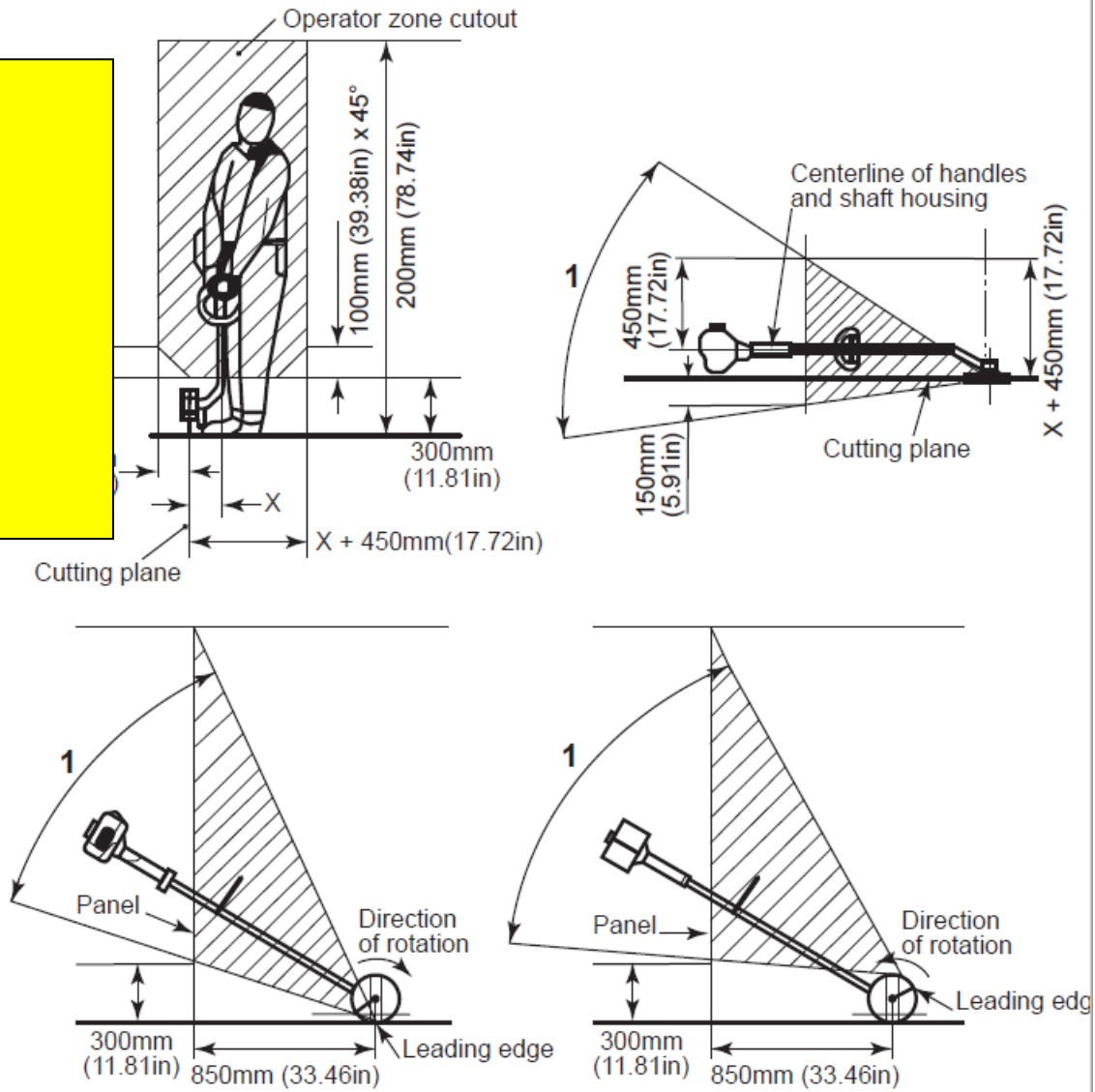

**Key**

1 No sight to leading edge of blade

**Notes**

X may vary on different models  
 Tolerances for shown dimensions  $\pm 5\text{mm}$

**Figure 6: Operator Thrown Object Protection Test**

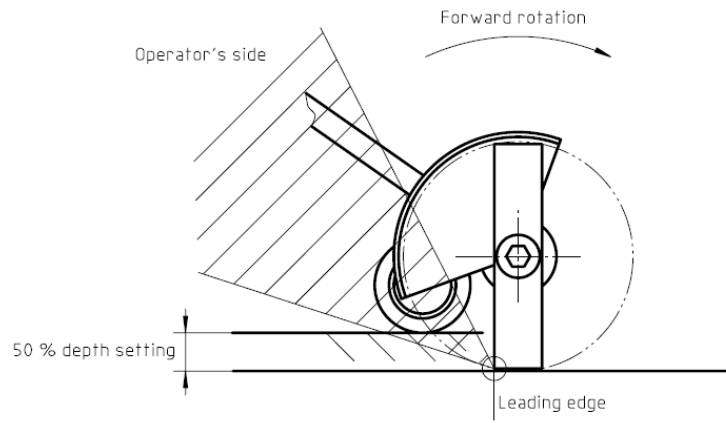

a) Forward rotating blade

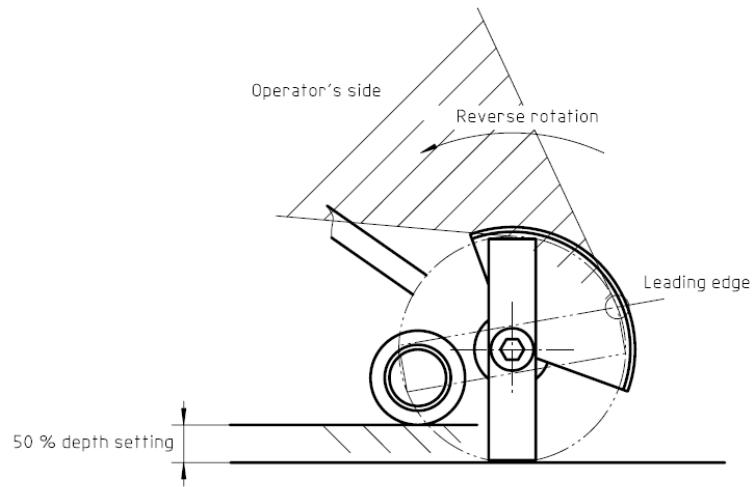

b) Reverse rotating blade

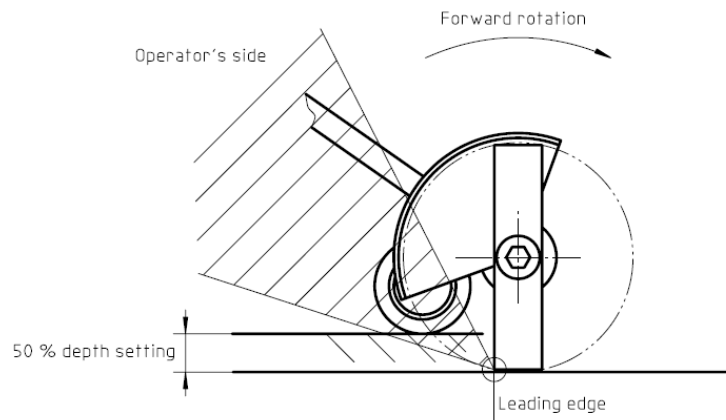

a) Forward rotating blade

## Figure 7: Depth Setting

# 10. Blade and Blade Retainer Integrity

## 10.1. Impact Test

### 10.1.1. Requirements

The blade, or its retainer shall not ~~become detached, break, crack or separate when tested in accordance with Section 10.1.2. Any breakage or cracking of the blade or blade retainer shall be considered as failure of the test. Chipping of the blade cutting edge is not considered a test failure.~~

Note: Damage to the blade at the point of contact may be expected and is not a cause of test failure.

### 10.1.2. Test Procedures

~~The engine shall be operated at the maximum engine speed.~~

The unit shall be suspended freely in the operating position and allowed to swing in an arc as shown in Figure 8.

A horizontally positioned rigidly supported mild cold rolled steel rod (for example SAE 1010-1040) with a diameter of 25 mm  $\pm 1.3$  mm ~~(9.81.0 in  $\pm 0.05$  in)~~ shall be vertically impacted by the ~~cutting attachment blade~~ at a minimum approach speed of 1.0 m/s  $\pm 0.1$  m/s ~~(40-39.37 in/s  $\pm 3.94$  in/s), which may be (1) measured or (2) estimated by letting the unit swing from the drop height calculated by Formula 1. The approach speed may be measured or determined by using the calculated drop height.~~

When using Formula 1 to determine a drop height, The the calculations shall be made such that the unit center of gravity shall be at its lowest point at blade contact with the bar.

~~The engine shall be switched off 1 s after impact.~~

~~Determine the drop height from:~~

where  $h$  is the drop height, in meters;  $r_1$  and  $r_2$  are as shown in Figure 8, in meters.

Formula 1 – Blade and blade retainer integrity drop height calculation

The test shall be conducted with the unit operating at the maximum engine speed. The engine shall be switched off 1 second after impact.

NOTE — The test does not require that the unit is suitable for use after the test.



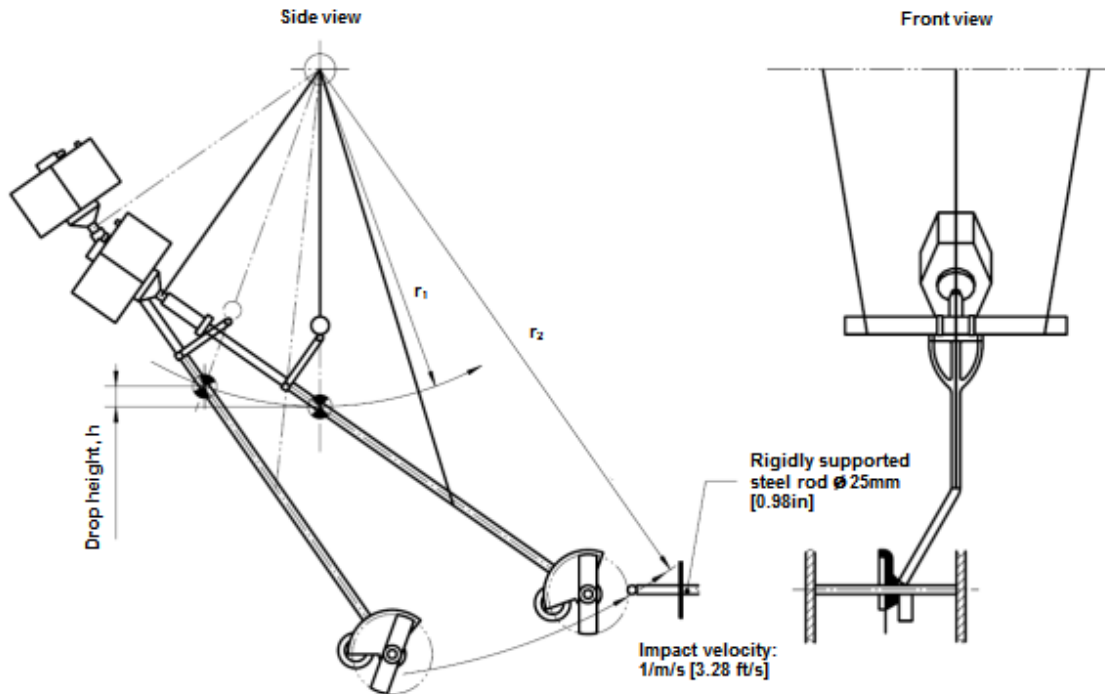

**Figure 8: Example of Blade Impact Test**

## 10.2. Blade Retention

### 10.2.1. Requirements

The blade fastening system shall provide tension to the blade to prevent movement during normal use. The blade attachment shall withstand the test torque,  $M_{T-1}$  described in Section 10.2.2.

The fastening system shall be designed to protect against the blade becoming detached from the unit by:

- A fastening system that is tightened by the driving torque of the units; or
- A fastening system secured by a method not acted upon by rotational forces.

Verification shall be by visual inspection following the torque testing in Section 10.2.2.

### 10.2.2. Test Procedure

- a) Install the cutting attachment blade in accordance with the manufacturer's recommendations.
- b) Lock the power transmission shaft.
- c) Apply a rotational torque,  $M$  (N.m), to the cutting attachment blade.

$$M \text{ (N.m)} = 0.4 \times V \times k$$

Or

$$M \text{ (lbf.ft)} = (4.84 \times V \times k)$$

Where,

$V$  is the engine displacement in  $\text{cm}^3$  ( $\text{in}^3$ )

$k$  is the gear ratio

- d) Conduct the test five times in the direction opposite to normal rotation, then five times in the direction of normal rotation.

## 11. ON/OFF or Stop Control

### 11.1. Requirements

The edger shall be equipped with an engine stop control stopping device that brings the engine to a complete stop ~~without sustained manual effort for its operation. This~~ The control for this device shall be so positioned that it can be operated while the unit is being held with both hands ~~by an operator with and without gloves., and its operation shall not depend on sustained manual effort.~~

The purpose and method of operation of the device shall be clearly and durably marked. The color of the control shall contrast to the background.

### 11.2. Test Procedure

Operation and marking of the stopping device shall be verified by inspection.

## 12. Electrical Protection

### 12.1. Requirements

All high-voltage parts of the circuit, including spark-plug terminals, shall be ~~electrically protected in such a manner that the operator cannot make accidental contact with them located, insulated or guarded so that the operator cannot come into accidental contact with them.~~

Ignition interruption or short-circuiting shall be provided and shall be fitted on the low-voltage side.

## 12.2. Test Procedure

The location and insulation of the parts under high voltage shall be verified by inspection, using a standard test finger, in accordance with UL 60745-1, Figure 1. The ignition interruption or short-circuiting shall be verified by inspection.

## 13. Clutches

### 13.1. Requirements

~~The edger shall have a clutch so designed that the cutting attachment does not move when the engine rotates at any speed less than 1.25 times the idling speed. Correct operation of the clutch shall be verified by inspection when increasing the engine speed from idling speed to 1.25 times the highest idling speed as specified by the manufacturer.~~  
The edger shall have a clutch that disengages power to the blade when the engine speed is reduced to the manufacturer's recommended idling speed.

### 13.2. Test Procedure

Operation of the clutch shall be verified by inspection with the engine idle speed adjusted in accordance with the manufacturer's recommendations. The throttle latch (if equipped) shall be disengaged.

## 14. Throttle Control / Throttle Control Latch

### 14.1. Throttle Control

#### 14.1.1. Requirements

The edger shall be equipped with a continuous-pressure throttle control system that, when released, automatically reverts to the idling position, unless the throttle control latch (if provided) is engaged for starting.

The throttle control linkage(s) shall be constructed so that a force ~~in the amount of three times the dry weight of the edger,~~ applied ~~in any direction~~ on the rear handle, does not increase the engine speed to a point at which the clutch engages and blade movement begins.

#### 14.1.2. Test Procedure

Operation of the throttle control function shall be verified by inspection.

Operation of the throttle control linkage(s) shall be verified by applying a force in the amount of three times the dry weight of the edger, in any direction on the rear handle.

## 14.2. Throttle Control Latch

### 14.2.1. Requirements

The edger may be equipped with a throttle control latch to aid in starting the engine.

If a throttle control latch is provided for starting, it shall be self-releasing when the throttle control is depressed. In the starting mode the blade may be powered. The throttle control latch shall be constructed so that two or more independent motions are required to engage the latch. A one-motion throttle control latch is acceptable, provided that it does not cause the blade to be powered.

### 14.2.2. Test Procedure

Operation of the throttle control latch shall be verified by inspection.

## 14.3. Throttle Control Lock-out

### 14.3.1. Requirements

A throttle control lock-out shall be provided, and it shall be constructed so that it must be actuated before the throttle control can be activated. When the throttle control system is locked out, the throttle control valve shall be in the idle position unless a throttle control latch is engaged (for starting). The throttle control lockout shall not prevent the engine from returning to idle speed.

The cutting blade shall not engage or move when a-the force is-described in Section 14.3.2 is applied to the throttle control without releasing the throttle lock-out.

### 14.3.2. Test Procedure

The throttle control lock-out function shall be verified by applying a force equal to  $50\text{ N} \pm 2\text{ N}$  ( $11.24\text{ lbf} \pm 0.45\text{ lbf}$ ) or the dry weight of the unit, whichever is higher, on the throttle control with the throttle control lock-out engaged. During the test the hand grip shall be fixed, without contacting the throttle control lock-out as shown in Figure 9. The force shall be applied gradually to the throttle control in the direction of travel and held for  $5\text{ s} \pm 1\text{ s}$ . For pivoting throttle controls the force shall be applied at the point furthest from the pivot and for linear operating throttle controls the force shall be applied at the midpoint of the throttle control. See Figure 9.

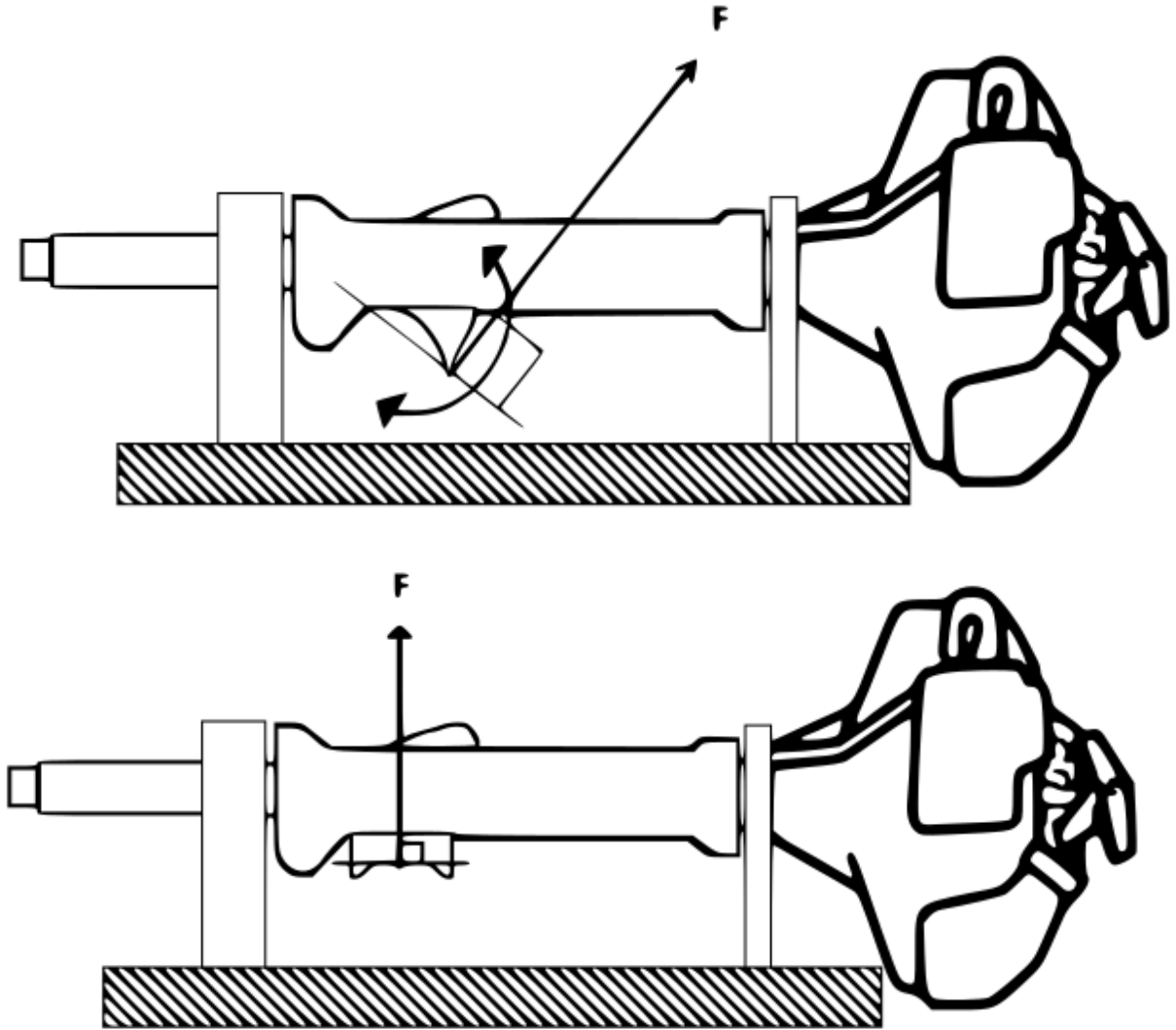

Figure 9: Throttle Control Lock-out Performance Test Direction of Throttle Control Force

## 15. Sound Levels

### 15.1. Requirements

Should the sound pressure level  $L_{peq}$  measured at the operator's ear ~~per ISO 22868~~ exceed 85 dB(A), the unit shall be labeled with an instruction to use operator hearing protection (written ~~or~~ pictorial).

The unit may be clearly and durably marked with the bystander sound pressure level ~~as indicated in~~ accordance to Annex B.

If so marked, the bystander sound level shall be identified in decibels [dB(A)] using simple block characters at least 6 mm (0.25 in) high. The wording "per ANSI OPEI

B175.5” or “per ANSI B175.5” in 2 mm (0.08”) minimum-height letters shall accompany the numerical sound pressure level.

**15.2. Test Procedures**

Sound pressure level  $L_{\text{peq}}$  at the operator’s ear shall be measured per ISO 22868.

If bystander sound pressure is marked, it shall be measured as indicated in Annex B.

Labeling shall be verified by inspection.

## **16. Vibration**

**16.1. Requirements**

The vibration total value  $a_{\text{hyv,eq}}$  from three orthogonal axes for each handle shall not exceed 12 m/s<sup>2</sup> (39.4 ft/s<sup>2</sup>) ~~when tested in accordance with ISO 22867~~. Units intended for occasional use shall be excluded from this requirement.

**16.2. Test Procedure**

Vibration for each handle shall be tested in accordance with ISO 22867.

## **17. Fuel Tanks, Fuel Lines and Oil Tanks**

**17.1. Tank Filler Location and Identification**

**17.1.1. Requirements**

The fuel tank filler opening and the oil tank filler opening, if provided, shall be located so that they will not be unduly obstructed by other edger components. Each cap or opening shall be clearly and durably identified. If only the caps are identified, they shall not be interchangeable.

**17.1.2. Test Procedure**

Tank filler location and identification shall be verified by inspection.

**17.2. Tank Filler Openings**

**17.2.1. Requirements**

The minimum diameter of the fuel tank filler hole shall be 20 mm (0.80 in). The minimum diameter of the oil tank filler hole, if provided, shall be 15 mm (0.60 in). The design of the caps shall be such that no leakage occurs while the unit is being used at normal operating temperature, in all working positions, and while being transported. The fuel cap shall have a retainer.

**17.2.2. Test Procedure**

Tank filler openings shall be verified by inspection.

**17.3. Fuel Tank Ventilation**

### 17.3.1. Requirements

If the fuel system is equipped with a ventilation-system, it shall not ~~lead-leak~~ under normal operation in accordance with the manufacturer's recommendation. Evaporation through the tank ventilation system is not regarded as leaking.

### 17.3.2. Test Procedure

Fuel tank ventilation shall be verified by inspection.

## 17.4. Fuel Tank Integrity

### 17.4.1. Requirements

The material used for the tank shall be resistant to fuels, oils and environments expected for use ~~in-of~~ the unit as described by the manufacturer in the operator's manual.

### 17.4.2. Test Procedure

~~Tanks~~ Fuel tank integrity shall be evaluated according to Annex C.2.

~~No visible tank leakage shall occur while holding the product for 30 s in each of the 6-orthogonal directions after subjecting test samples to the test described in Annex C.~~

## 17.5. Fuel Feed Line Integrity

### 17.5.1. Requirements

The fuel feed lines used in the unit shall be resistant to fuels, oils and environments expected for use of the unit as described by the manufacturer in the operator's manual. ~~Lines shall be evaluated according to Annex C.1.~~

The lines shall be routed so that they are not subject to direct abrasion when located outside of the tank.

### 17.5.2. Test Procedure

Fuel feed lines integrity shall be evaluated according to Annex C.1.

Fuel line routing shall be verified by inspection.

## 17.6. Fuel Feed Line Strength and Accessibility

### 17.6.1. Requirements

Fuel feed lines accessible by the probe in Figure 10 shall not break, crack, leak or become detached from their fittings or connections. ~~when tested in accordance with Annex C.1.~~

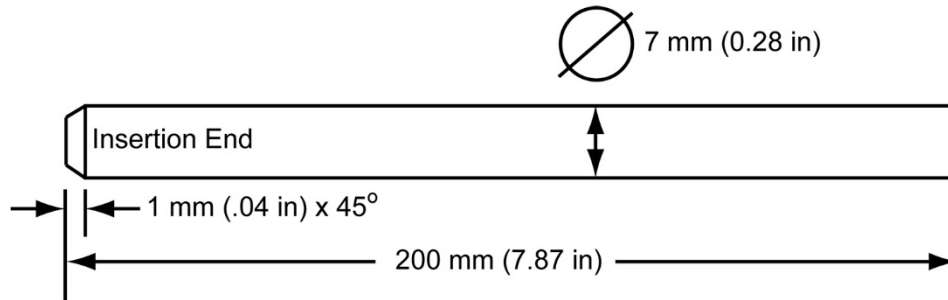

**Figure 10: Probe for fuel feed line testing**

### 17.6.2. Test Procedure

Fuel feed line strength and accessibility shall be evaluated in accordance with Annex C.1.

## 17.7. Structural Integrity of Fuel Tanks

### 17.7.1. Requirements

No visible tank leakage shall occur while holding the unit for 30 seconds in each of the six orthogonal directions after being tested in accordance with Section 17.7.2.

### 17.7.2. Test Procedure

- Equip the unit in accordance with the operator's manual.
- Fill the fuel tank half full with a mix of 50% glycol and 50% water. Condition the unit at  $-5\text{ }^{\circ}\text{C} \pm 5\text{ }^{\circ}\text{C}$  ( $23\text{ }^{\circ}\text{F} \pm 9\text{ }^{\circ}\text{F}$ ) for a minimum of 6 hours.
- Suspend the unit at the suspension height as described in ~~below~~ Section 17.7.3.
- Within one minute from coming out from the conditioning environment, drop the complete unit onto a concrete surface.

*NOTE: To collect any liquid that may leak out as a result of the test, concrete slabs placed in a metal tray, in turn placed on the concrete surface, may be used.*

- Two impacts shall be performed. Defective parts, excluding the fuel tank, may be replaced. The unit shall be reconditioned to the test temperature for the second drop if both impacts cannot be performed within 1 minute.

### 17.7.3. Suspension Height

Suspend the edger complete with cutting blade by means of a string attached to the mid-point of the rear handle. The lower part of the handle surface or the suspension point, whatever case is applicable, shall be  $775\text{ mm} \pm 5\text{ mm}$  ( $30.5\text{ in} \pm 0.2\text{ in}$ ) above the hard impact surface with the unit in a normal position in accordance with Figure 3. ~~If the tank is exposed, the unit shall be suspended in such a manner so as to most likely cause the exposed tank surface to contact the ground at impact. The support wheel~~



and/or blade may contact the ground in the suspended position. It is not required that the tank contact the ground at impact if the natural tendency of the unit design reorients the unit after it is released.

## 18. Labeling Requirements

The edger shall be clearly and durably labeled or marked with wording or suitably paraphrased wording as described in Sections 18.1 through 18.6 ~~below~~. Symbols may be used to provide the information requirements in this section and shall be explained in the operator's manual(s).

In addition, the unit shall be marked with the rotational cutting direction for the ~~cutting-attachmentblade~~ on a component near the ~~cutting the attachmentblade~~. The ~~cutting-attachmentblade~~ shall be marked with the rotational direction, when applicable.

The warnings shall be located in a readily visible position on the unit and shall resist the anticipated service conditions, e.g. the effect of temperature, moisture, petrol, oil, abrasion and weathering exposure.

To comply with ~~the~~ durability requirements, the labels on the unit shall be tested according to ISO 11806:~~2011~~, or ANSI/UL 969:~~2012~~ supplemented by a gasoline exposure test.

When symbols are used, they shall, except if they are cast, embossed or stamped, be in contrast to their background. Embossed features shall be at least 0.3 mm (0.01 in) in height. The information and/or instructions provided by the symbols shall be clearly legible when viewed by the naked eye from a distance of not less than 500 mm (19.6 in).

- 18.1. WARNING!** Read the operator's manual(s) and follow all warnings and safety instructions. Failure to do so can result in serious injury to the operator and/or bystanders.
- 18.2.** Warn the operator of thrown objects such as ricochet.
- 18.3.** Warn the operator to keep bystanders at least 15 m (50 ft) away.
- 18.4.** Inform the operator to wear eye protection that complies with ANSI Z87.1.
- 18.5.** Wear hearing protection (if applicable as set forth in Section 15). Bystander sound pressure XX dB(A) (if applicable as set forth in Section 15).
- 18.6.** Inform the operator to wear foot protection and gloves.

## 19. Operator's Manual(s) Instructions

Safety, operating and maintenance instructions and technical data as listed shall be made available for every unit.

If any portion of this information is not provided with the unit, the website or company contact information, with instructions on how this information can be obtained, shall be provided with the unit.

### **19.1. General Information**

The operator's manual(s) shall provide sufficient information to enable the operator to assemble and maintain the unit throughout the life of the product.

The operator's manual(s) shall explain the consequences of improper maintenance, use of nonconforming replacement components, and the modification or removal of components.

The operator's manual(s) shall indicate the tasks for which the unit may be used. It shall recommend **cutting attachmentblade**(s) for the unit. The manual(s) shall also recommend proper cutting techniques, and the materials that can be cut with the unit. The manual(s) shall warn of the hazards of blade thrust and recommended unit configuration for blade use.

The operator's manual(s) shall include the information requirements set forth in Section 18.

A unit intended for occasional use shall be so identified in the manufacturer's operator's manual(s).

### **19.2. General Instructions**

The operator's manual(s) shall provide the warnings and safety instructions listed below, verbatim or suitably paraphrased. These shall be of a form readable and legible and with a letter size of not less than 2.0 mm (0.08 in).

#### **19.2.1. Physical Condition of Operator**

Do not operate this unit when tired, ill or under the influence of alcohol, drugs, or medication.

#### **19.2.2. Clothing Recommendation**

Always wear long pants, boots, gloves and a long-sleeve shirt. Do not wear loose clothing, jewelry, short pants, sandals, or go barefoot. Secure hair so it is above shoulder level.

#### **19.2.3. Condition of the Unit Before Use**

Inspect unit before each use. Replace damaged parts. Check for fuel leaks. Make sure all fasteners are in place and secure. Replace **cutting attachment partsblades** that are cracked, chipped, or damaged in any way. Make sure the **cutting attachmentblade** is properly installed and securely fastened. Be sure the **cutting attachmentblade** shield is properly attached and in the position recommended by the manufacturer.

#### **19.2.4. Proper Stance**

Maintain firm footing and balance. Do not over-reach. Maintain all parts of your body away from the ~~cutting-attachmentblade~~ and hot surfaces.

#### **19.2.5. Exhaust Gases**

Do not operate the unit inside a closed environment, such as a room or building; breathing carbon monoxide from exhaust fumes can kill.

#### **19.2.6. Fueling**

Use caution when handling fuel. Mix and pour fuel outdoors where there are no sparks and flames. Slowly remove the fuel cap only after stopping the engine and allowing the unit to cool. Do not smoke while fueling or mixing fuel. ~~Wipe spilled fuel from the unit.~~ Move the unit at least 3 m (10 ft) away from the fueling ~~source and sitepoint~~ before starting the engine.

#### **19.2.7. Operating Area**

Operate the unit only in daylight or good artificial light.

Clean the area to be cut before each use. Remove all objects, such as rocks, broken glass, nails, wire or string, which can be thrown or become entangled in the ~~cutting-attachmentblade~~. Clear the area of children, bystanders and pets. At a minimum, keep all children, bystanders, and pets outside a 15 m (50 ft) radius; Outside the 15 m (50 ft) zone, there is still risk of injury. Bystanders should be encouraged to wear eye protection. Be aware that children, bystanders and pets may approach from behind. If you are approached, stop the engine.

#### **19.2.8. Idle Speed Adjustment (if applicable)**

The ~~cutting-attachmentblade~~ may be spinning during carburetor adjustments. Wear your protective equipment and observe all safety instructions. ~~For units equipped with a clutch, be~~Be sure the ~~cutting-attachmentblade~~ stops turning when the engine idles. When the unit is turned off make sure the ~~cutting-attachmentblade~~ has stopped before the unit is set down.

#### **19.2.9. Transportation and Storage of the Unit**

Provide transportation and long- and short-term storage instructions.

#### **19.2.10. Blade Thrust**

Warn the operator of the danger of blade thrust:

- Blade thrust may occur when the spinning blade contacts an object that it does not immediately cut.
- Blade thrust can cause the operator to lose control of the unit.
- Blade thrust can occur without warning if the blade snags, stalls or binds.

- Blade thrust is more likely to occur in areas where it is difficult to see the material being cut.

#### **19.2.11. Condition of Unit Before Use**

The handles shall be mounted in accordance with the manufacturer's instructions. Do not attach any blade to a unit without proper installation of all required parts. Failure to use the proper parts can cause the blade to fly off and seriously injure the operator and/or bystanders. Discard blades that are bent, warped, cracked, broken or damaged in any way. Use a sharp blade. A dull blade is more likely to snag and thrust.

#### **19.2.12. Blade Maintenance**

If a manufacturer indicates an operator may sharpen a metal blade, proper instructions and warnings shall be provided. Wear protective gloves when handling or performing maintenance on the blade.

#### **19.2.13. Stopping the Unit**

A coasting blade can cause injury while it continues to spin after the engine is stopped or throttle trigger is released. Maintain proper control and stance, and do not move the edger outside of the operating area until the blade has completely stopped rotating.

**Annex A**  
**Procedure to Determine Hot Surfaces (Section 6)**  
**(Normative)**

**A.1 Determination of hot surfaces**

The test cone shown in Figure 4 shall be moved in any possible direction towards the hot surfaces specified for testing.

Mark the areas touchable with the test cone tip or conical surface. If the touchable area is interrupted, determine the hot surface area as described in A.3.

**A.2 Determination of temperature of hot surfaces**

Measure the temperatures of the hot surfaces identified in A.1.

The temperature (T) shall be determined by correcting the measured temperature (TM) depending on the ambient temperature (TA) at the time of the test as follows:

$$T = TM - TA + 20 \text{ }^{\circ}\text{C} (68 \text{ }^{\circ}\text{F})$$

where

TM = measured temperature in  $^{\circ}\text{C}$  or in degrees Fahrenheit ( $^{\circ}\text{F}$ ), as applicable

TA = ambient temperature in  $^{\circ}\text{C}$  or in degrees Fahrenheit ( $^{\circ}\text{F}$ ), as applicable

Determine temperatures using temperature measuring equipment with an accuracy of  $\pm 2 \text{ }^{\circ}\text{C}$  ( $\pm 3.6 \text{ }^{\circ}\text{F}$ ).

Mark the surfaces with temperatures higher than  $80 \text{ }^{\circ}\text{C}$  ( $176 \text{ }^{\circ}\text{F}$ ) for metallic surfaces or higher than  $94 \text{ }^{\circ}\text{C}$  ( $201 \text{ }^{\circ}\text{F}$ ) for plastic parts.

Measure and record the area of the marked surface(s). If the area is interrupted the procedure in A.3 shall be followed.

**A.3 Determination of area for interrupted surfaces**

If a marked surface (with area A1) consists of multiple separate surfaces of which the sum of the areas (A2) exceeds 80% of A1, then A1 shall be considered as one uninterrupted area. See Figure A.1.

Surfaces whose structure does not allow a ball with 2 mm (0.04 in) diameter to penetrate more than 2 mm (0.04 in) below highest parts of the structure shall be considered as part of A1. See Figure A.1.

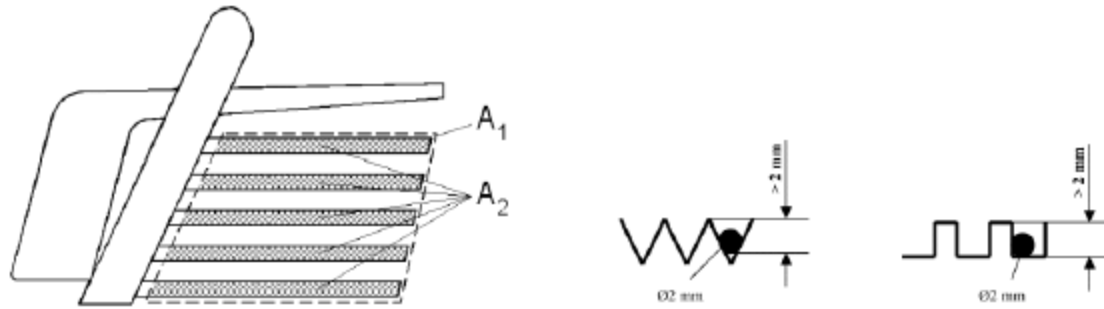

**Key**

A1 marked surface area

A2 sum of the areas  $> 80\%$  of A1

**Figure A.1: Example of a surface consisting of multiple separate surfaces**

If a marked surface (with area A1) includes holes of which the sum of the areas (A3) is less than 20% of the area of marked surface (A1) it shall be considered as one uninterrupted area. See Figure C.2.

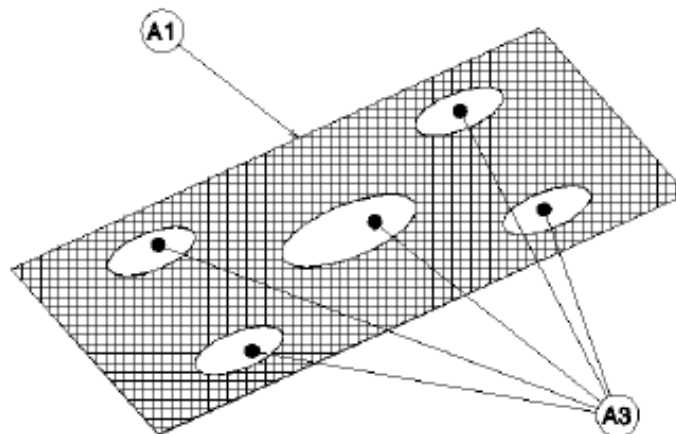

**Key**

A1 marked surface area

A3 sum of the areas of holes

**Figure A.2: Example of a surface with holes**

## **Annex B**

### **Sound Test Procedures (Section 15)**

#### **(Normative)**

### **B.1 Test values**

The values to be measured shall be A-weighted sound pressure levels, in decibels, determined with the frequency weighting "A" and slow response as defined in IEC 61672-1 and [615726172-2](#).

### **B.2 Test site**

#### **B.2.1 Measurement of sound pressure in free field**

- a) The test area shall be a flat, open space with natural ground cover not exceeding 80 mm (3 in) in height, and free of any large reflecting surfaces such as signboards or buildings for a minimum distance of 30 m (100 ft) from the unit and microphone.
- b) The ambient sound level at the point of measurement (including wind effects) coming from sources other than the unit being tested shall be at least 10 dB(A) lower than the sound level of the unit.
- c) Measurements shall be made only when wind gusts are below 5.4 m/s (12 mph).

Note: For single microphone test set-ups the wind direction shall be approximately perpendicular ( $\pm 45$  degrees) to a line between the microphone and the test unit (see figure A.1).

- d) The ambient air temperature shall be 5 °C (41 °F), or greater, at the time of test.

#### **B.2.2 Measurement of sound in sound room (alternate method)**

- a) An anechoic or semi-anechoic chamber may be used for conducting a sound level test provided the test results do not vary more than  $\pm 1$  dB(A) from the free field test results. If the variation exceeds  $\pm 1$  dB(A), the correction between the sound room measurement and free field sound measurement shall be applied to the result obtained from the sound room.
- b) Sound levels for distances exceeding the dimensions of the chamber may be calculated from measurements taken in the chamber if sufficient data is available to substantiate such calculations. Artificial grass (e.g., "Astro-Turf") is acceptable as floor covering in the chamber.

### **B.3 Test and unit conditions**

- a) The unit shall be evaluated with all the standard attachments included with the unit by the manufacturer. The attachments shall be mounted in accordance with the manufacturer's instructions.

- b) All readings shall be taken with the unit running at maximum engine speed and in a normal operating position with the cutting blade held perpendicular to the ground with the lowest part of the cutting blade at least 50 mm (2 in) but no more than 305 mm (12 in) above the ground cover.
- c) The unit shall be tested warmed up with the carburetor adjusted in accordance with the manufacturer's recommendations.

## **B.4 Instrumentation**

### **B.4.1 Calibration**

- a) Before and after each series of measurements, an acoustical calibrator with an accuracy of at least +0.5 dB(A) shall be applied to the microphone to check the calibration of the entire measuring system at one or more frequencies in the range from 200 to 1000 Hz.
- b) The calibrator shall be checked at least once every year to verify that its output is within specifications.
- c) The measuring equipment shall be allowed to reach a steady state (stabilized) temperature before it is calibrated.

### **B.4.2 Engine speed indicator**

An engine speed indicator shall be used to check the speed of the engine. It shall have an accuracy of  $\pm 3\%$  of the measured value.

### **B.4.3 Microphone**

Suitable measuring devices are sound level meters meeting or exceeding the requirements of a Class 1 instrument in accordance with IEC 61672-1. It is recommended that a microphone with a diameter not greater than 13 mm (0.5 in) be used for the measurements. ~~A wind screening attachment to the microphone may be used, if this is allowed for, if necessary, in the calibration and does not alter the measured sound level by more than 0.5 dB(A) as a consequence of its effect on the omni-directional characteristics of the microphone.~~

A wind screening attachment to the microphone may be used if necessary and allowed per relevant standards. Such an attachment may be used during calibration of the microphone provided it does not alter the sound level by more than 0.5 dB(A) as a consequence of its effect on the omnidirectional characteristics of the microphone.

### **B.4.4 Meter**

Either of the following systems may be used:

- a) A precision sound level meter that meets the Class I requirements of IEC 61672-1 for direct measurements.
- b) A data acquisition system that meets the requirements of SAE-J184.



### **B.5 Microphone position (bystander sound pressure)**

- a) The microphone shall be placed 15 m (50 ft) from the operator and 1.2 m (4 ft) above ground. If an anechoic chamber is used and the 15 m (50 ft) distance cannot be met, the distance may be shortened provided the resulting measurements are corrected to yield results for 15 m (50 ft).
- b) The microphone shall be positioned with its axis of highest sensitivity generally parallel to the ground and pointed toward the unit operator.

### **B.6 Other influences**

Not more than one person, other than the observer reading the meter, shall be within 17.7 m (58 ft) of the unit, and that person shall be directly behind the observer reading the meter, in line with the microphone and the observer. The individual reading the meter shall be at least 2.4 m (8 ft) behind the microphone. All other observers shall be no closer than 30.5 m (100 ft) to the unit or microphone.

### **B.7 Test procedure (bystander sound pressure)**

- a) Measurements shall be taken at every 45 degrees (a total of 8 different positions). Five readings shall be taken at each position ~~for-at~~with at least 5 seconds ~~apart~~between each reading. Each reading shall be an average of at least 2 seconds duration. The arithmetic average of the five readings is to be used in the calculation of the reported sound level. If the test data at each position vary more than 2 dB-(A), the test shall be repeated until five sequential readings are within 2 dB-(A) at each measuring position. If an analog sound level meter is used, the average of the highest and the lowest indicated readings shall be used.
- b) The unit shall rotate 360 degrees with respect to the microphone in a fixed position. Alternately, an array of 8 microphones may be used and all data may be collected at one time.
- c) The reported sound level shall be the arithmetic average of the eight averaged readings taken and rounded to the nearest whole decibel (ANSI/ASTM E29).
- d) The engine speed during the measurements shall be kept within  $\pm 120$  rpm.

### **B.8 Information to be recorded (see Figure B.1 in this Annex for sample data sheets)**

#### **B.8.1 Unit under test**

Description of the unit (including engine displacement, manufacturer, type, serial number, and attachments).

#### **B.8.2 Test environment**

- a) Describe the test environment.

- b) If outdoors, sketch the location of the engine with respect to surrounding terrain, including a physical description of the test environment (the nature of the ground plane shall be described).
- c) If indoors, provide a correlation figure between indoor and outdoor measurement.

### **B.8.3 Instrumentation**

- a) Equipment used for the measurements, including name, type, serial number and manufacturer.
- b) Date and place of the most recent calibration of the acoustical calibrator.

### **B.8.4 Test data**

- a) The location of the microphone position (a sketch or photograph may be included, if necessary.)
- b) The sound pressure levels of the background noise.
- c) Engine speed, measurement values and arithmetic averages.
- d) Air temperature, wind speed, and barometric pressure.
- e) The date and place of the measurements.

Ambient Conditions	
Temperature	
Baro. Press.	
R. Humidity	
Wind (mph)	
Noise (dB(A))	
DATE	
Manufacturer Sound Level Meter (S/N: xxxx) / Manufacturer Microphone (S/N: xxxx)	
Test Was Conducted by:	
Date of last calibration of acoustical calibrator:	
Location of Test:	
Pipe Configuration Tested:	

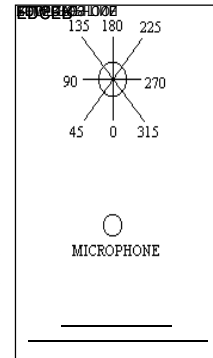
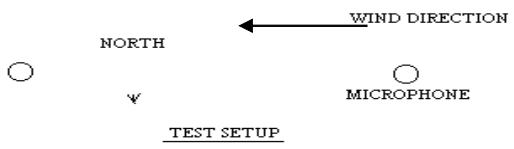

Model #	SERIAL #	RPM=			
Position (Deg)	Sound Pres. Readings (dB(A))				Average
0					
45					
90					
135					
180					
225					
270					
315					
				Average:	
				Label value:	

Position (Deg)	Sound Pres. Readings (X10 <sup>-6</sup> Pa)				
0	20.0	20.0	20.0	20.0	20.0
45	20.0	20.0	20.0	20.0	20.0
90	20.0	20.0	20.0	20.0	20.0
135	20.0	20.0	20.0	20.0	20.0
180	20.0	20.0	20.0	20.0	20.0
225	20.0	20.0	20.0	20.0	20.0
270	20.0	20.0	20.0	20.0	20.0
315	20.0	20.0	20.0	20.0	20.0

AVG. (X10 <sup>-6</sup> Pa)	dB(A)
20.0	0.0
20.0	0.0
20.0	0.0
20.0	0.0
20.0	0.0
20.0	0.0
20.0	0.0
20.0	0.0
20.0	0.0
20.0	0.0
AVERAGE=	0.0
<b>LABEL VALUE=</b>	<b>0</b>

<b>CALIBRATION BEFORE TEST</b>	d(B)A
<b>CALIBRATION AFTER TEST</b>	d(B)A

Figure B.1: Sample edger bystander sound level data sheet

**Annex C**  
**Procedures for the Evaluation of Environmental and Fuel Compatibility of Fuel**  
**Feed Lines and Fuel Tanks (Section 17)**  
**(Normative)**

**C.1 Fuel line integrity**

**C.1.1 Fuel resistance**

The fuel line shall be filled with a 10% ethanol fuel for 168 hours. For example, gasoline (E0) splash blended with ethanol. The ambient temperature for the soak period shall be  $40\text{ }^{\circ}\text{C} \pm 5\text{ }^{\circ}\text{C}$  ( $104\text{ }^{\circ}\text{F} \pm 9\text{ }^{\circ}\text{F}$ ). The line shall be removed from the fuel and allowed to air dry at  $80\text{ }^{\circ}\text{C}$  ( $176\text{ }^{\circ}\text{F}$ ) for four hours. The fuel line shall develop no visible cracks when bent (without stretching or elongating) around a 25.4 mm (1 in) diameter rod and being examined with the naked eye.

Metallic or FKM grade rubber (i.e., Viton) material lines are exempted from this test.

**C.1.2 Ozone resistance**

The test shall be performed in accordance to ISO 1431-1 static strain test. Testing can be performed either with the test piece described in 6.3 of ISO 1431-1 with 20% elongation to qualify the material in general or a complete fuel line in the geometry as installed and tested on the engine. The fuel line shall develop no visible cracks when bent around a 25.4 mm (1 in) diameter rod and being examined with the naked eye.

The test conditions shall be as follows:

- Temperature:  $40\text{ }^{\circ}\text{C} \pm 2\text{ }^{\circ}\text{C}$  ( $104\text{ }^{\circ}\text{F} \pm 4\text{ }^{\circ}\text{F}$ )
- Humidity: 20 to 65%
- Ozone: 50 pphm  $\pm$  5 pphm
- Time: 72 h

Metallic or FKM grade rubber (i.e., Viton) material lines are exempted from this test.

**C.1.3 UV resistance**

Perform a sunlight - exposure test by exposing the line to an ultraviolet light of at least  $24\text{ W/m}^2$  or natural sunlight on the line surface for at least 450 hours.

No surface cracking shall be visible with the naked eye after the UV exposure test.

Lines which are not exposed to direct sunlight, metallic or FKM grade rubber (i.e., Viton) material lines are exempted from this test.

**C.1.4 Strength and accessibility**

Fuel line strength and accessibility shall be determined by the use of a 7 mm diameter x

200 mm (0.28 in diameter x 7.88 in) test probe (Figure 10) mounted to a force meter. All guards and covers shall be installed for the test and the test shall be conducted at room temperature ( $20\text{ }^{\circ}\text{C} \pm 5\text{ }^{\circ}\text{C}$  ( $68\text{ }^{\circ}\text{F} \pm 9\text{ }^{\circ}\text{F}$ )). The fuel lines and connections shall be preconditioned by completely filling the fuel tank and then running the engine for 5 minutes. Stop the engine and wait 24 hours prior to conducting the test.

The fuel line and connections shall be tested by inserting the test probe into any openings in the unit which can be used to access the lines. Fuel lines accessible with the tip of the test probe shall be tested by applying an axial force of  $40\text{ N} +0/-2\text{ N}$  ( $8.99\text{ lbf} +0/-0.45\text{ lbf}$ ). The test probe shall be mounted to a force meter. The force shall be applied to accessible fuel feed lines the probe contacts.

Flexing of the probe is acceptable during the test. Verification is by visual inspection. No fuel line shall become damaged, detached, or leak by the test. If the fuel lines remain intact after the probe test, briefly run the engine again and verify that no fuel leakage is observed.

The probe shall be made of a PA6 Nylon material without glass reinforcement. The probe represents branches in the working environment that might come into contact to the unit and possibly go into the openings of the unit.

## **C.2 Fuel tank integrity**

### **C.2.1 Fuel resistance**

The fuel tank shall be filled with a 10% ethanol fuel for 168 hours. For example, gasoline (E0) splash blended with ethanol. The ambient temperature for the soak period shall be  $40\text{ }^{\circ}\text{C} \pm 5\text{ }^{\circ}\text{C}$  ( $104\text{ }^{\circ}\text{F} \pm 9\text{ }^{\circ}\text{F}$ ). The tank shall be emptied of the fuel and allowed to air dry at  $80\text{ }^{\circ}\text{C}$  ( $176\text{ }^{\circ}\text{F}$ ) for four hours. ~~The tank shall have developed no cracks or leaks.~~ The cap and sealing gasket for the fuel tank shall be installed for the test.

For tanks utilizing the same material, color, manufacturing process and thickness, the manufacturer may select a single tank to represent all tanks when conducting this test. The tank test shall have the largest internal surface area per volume ratio of the family.

At the conclusion of the test, the tank shall have developed no cracks or leaks.

### **C.2.2 UV resistance**

Perform a sunlight-exposure test by exposing all surfaces of the tank to an ultraviolet light of at least  $24\text{ W/m}^2$  or natural sunlight on the tank surface for at least 450 hours.

~~No surface cracking shall be visible with the naked eye after the UV exposure test.~~

Tank surfaces which are not exposed to direct sunlight, metallic tanks and tanks made of polyamide materials (or polyamide with a maximum of 35% glass) are exempted from this test.

For tanks utilizing the same material, color, manufacturing process and thickness, the manufacturer may select a single tank to represent all tanks when conducting this test.

At the conclusion of the test, ~~None~~ surface cracking shall be visible with the naked eye after the UV exposure test.